

ΟΔΗΓΙΕΣ ΧΡΗΣΗΣ: ΑΜΑΞΙΔΙΟ SCOOTER “APOLLO”
USER MANUAL: SCOOTER-TYPE FOLDABLE “APOLLO”
REF: 0811800



1. Preface	3
2. Safety Notice	4-5
3. Safety Guidelines	6
3.1 General	6
3.2 Product Safety Symbols	6
3.3 Modification	10
3.4 Safety Check	10
3.5 Weight Capacity	10
3.6 Transporting Your Scooter	10
3.7 Incline Guidelines	10
3.8 Outdoor Operation & Inclement Weather Precautions	11
3.9 Physical Limitations	11
3.10 EMI Information	11
3.11 Fireproof performance	12
4. Your Product	13
4.1 Manual Freewheel Lever	13
4.2 Battery Condition Meter	14
4.3 Throttle Control Lever	14
4.4 Key Switch	14
4.5 Speed Adjustment Dial	14
4.6 Horn Button	14
5. Operation	15
5.1 Before getting onto your travel scooter	15
5.2 Getting onto your travel scooter	15
5.3 Pre-Ride Adjustment and check	15
5.4 Operating your travel scooter	15
5.5 Getting off of your travel scooter	16
5.6 Power Down Timer Feature	16
6. Comfort Adjustment	17
6.1 Delta tiller And Rear View Mirrors Adjustment (Optional)	17
6.2 Tillers Angle Adjustment (Optional)	17
6.3 Seat Rotation Adjustment	18
6.4 Armrest Width Adjustment	18
6.5 Seat Height Adjustment	18
7. Disassembly And Assembly	19
7.1 Disassembly	19
7.2 Disassembly Procedures	19
7.3 Frame Separation	19
7.4 Assembly	20
8. Basic Troubleshooting	21
9. Batteries And Charging	22
9.1 First Charge	22
9.2 Charging Your Scooter	22
9.3 Operating Temperatures	22
9.4 Battery Operation and Charging	22
9.5 Charging Batteries	23

10. Care And Maintenance	24
10.1 Tire	24
10.2 Wheel Replacement	24
10.3 Exterior Surfaces	24
10.4 Cleaning and Disinfection	24
10.5 Battery Terminal Connections	24
10.7 Daily Checks	24
10.8 Weekly Checks	25
10.9 Monthly Checks	25
10.10 Yearly Checks	25
10.11 ABS Plastic Shrouds	25
10.12 Axle Bearings and The Motor/Transaxle Assembly	25
10.13 Console, Charger, and Rear Electronics	25
10.14 Nylon Lock Nut Replacement	26
10.15 Storing Your Travel Scooter	26
10.16 Disposal of Your Mobility scooter	26
11. Specifications	27
12. Warranty	29
12.1 Two (2) Year Limited Warranty	29
12.2 One (1) Year Limited Warranty	29
12.3 Not Covered Under Warranty	29
12.4 Batteries	29
12.5 Service Checks and Warranty Service	29
12.6 Replacement Units	29
Appendix I : EMC compliance information	30

Congratulations! You are now the owner of a **Apollo** scooter!

This scooter is made by qualified and committed personnel. It is designed and produced according to high-quality standards guarded by **MOBIAK**.

Please read this Owner's Manual before operating your scooter for the first time. Improper use of the scooter may result in harm, injury, or traffic accidents.

If you still have questions after reading this manual, do not hesitate to contact your specialist dealer. They will be glad to help you on this subject.



WARNING!

Improper use could lead to death, serious injury, hazardous conditions, or product malfunction.



ATTENTION!

Improper use could lead to injury and/or damage to your scooter.



SUGGESTION!

Follow these instructions for best practices, and to keep your scooter in prime operating order.

If someone else uses the mobility scooter, please provide a copy of the Owner's Manual for their consideration.

This Owner's Manual is composed of the product design and specifications at the time of publication. As design changes, some illustrations and pictures in the manual may not correspond to the scooter you purchased. We reserve the right to make design modifications.

The manufacturer disclaims all responsibilities for any personal injury or property damage that may occur due to improper or unsafe use of this product.

2. Safety Notice

- Be aware the device is a small mobility scooter and is designed mainly for indoor use. Extreme care should be taken when cornering and negotiating drops, obstacles, and gradients.
- Always ensure the mobility scooter is fully folded out before sitting on the scooter. Do not fold up the scooter until you have fully exited the scooter, and the backrest on the scooter seat is folded down, and the armrests are lowered to their lowest setting.
- The mobility scooter folding mechanism features an anti-entrapment function. This is primarily designed to prevent damage to the armrests and backrests. Folding will stop if the mobility scooter is folded while the user is sitting in the scooter, but some assistance may be required to unfold the scooter. For this reason, folding the scooter while occupied is strictly prohibited.
- Do not operate the folding mechanism while somebody is sitting on the seat.
- Read and follow the information in the owner's manual. Do not use this product or any available optional equipment without first thoroughly reading and understanding these instructions. If you cannot understand the warnings, cautions, or instructions, contact your dealer before attempting to use this equipment. Otherwise, injury or damage may occur. Never try to use your mobility scooter beyond its limitations, as described in this manual.
- Keep your feet on the footboard at all times during operation. Do not stand on the footboard.
- Only drive on flat surfaces where all four wheels touch the ground and have sufficient contact to operate the mobility scooter safely.
- If the battery gauge drops to red, charge the scooter as soon as possible. Completely discharging the batteries may damage the batteries or shorten the expected life of the batteries.
- Keep metal objects away from the battery terminals. Electric shock may occur.
- Always reduce your speed and maintain a stable center of gravity when cornering. Do not corner sharply when driving scooters at higher speeds, and reduce speed before cornering.
- Make sure that there are no obstacles behind you while reserving your mobility scooter.
- Do not allow children to play near or operate the scooter.
- Some of the parts of the mobility scooter are susceptible to change in temperature. The controller can only operate in temperature that ranges between $-10^{\circ}\text{C} \sim 50^{\circ}\text{C}$ (-14°F to 122°F).
- At extremely low temperatures, the batteries may freeze, and your mobility scooter may not be able to operate. In extremely high temperatures, it may operate at slower speeds due to a safety feature of the controller that prevents damage to the motors and other electrical components.
- Store in a clean and dry condition.
- Do not drive your scooter at night without proper lighting.
- Do not remove the anti-tip wheels or transit wheels.
- Keep your hands and feet away from moving parts while driving. Be aware of loose-fitting clothes that can become caught in the drive wheels.
- Surface temperatures can increase when exposed to external sources of heat.

2. Safety Notice

- Do not connect an extension cord to the battery charger.
- Disassembling the controller, motor, or charger by anyone other than an authorized service agent is prohibited and voids any applicable warranty.
- Do not take your mobility scooter on roads or highways.
- Do not use your mobility scooter if you are under the influence of alcohol, medicines, or other substances that may influence your driving abilities.
- Be cautious when driving your mobility scooter in busy areas or shopping malls.
- Under no circumstances should the mobility scooter be used as a seat in a motor vehicle.
- Do not attempt to lift your mobility scooter by any parts other than the frame (for example, seat or body shrouds)

3.1 General

Before operating your mobility scooter, fully read and understand this Owner's Manual.

Users may encounter difficult maneuvering situations such as narrow doorways, traveling up and down ramps, cornering, and traveling on uneven terrain. Be sure to lower the speed, take your time, and carefully maneuver the mobility scooter.

Scooter is designed for the easy transport of people. It is designed for the use of one person with maximum weight 136Kg, not passengers (including children). Electric scooter is designed for adults, not goods, and not for people under 16 years of age. Electric mobility scooter is a kind of transportation device, which compensates people with mobility difficulties.

Scooter consists of frame, motor, controller, battery, wheels, shell, hardware accessories and so on. The operator must read the product specification carefully and abide by its requirements before using it for the first time, otherwise, this product shall not be used.

This product is repeated use of medical devices many times. This product is used independently in clinic and is not used with other medical devices. This scooter is not suitable for hemiplegia or paraplegia and this scooter shall not be used for mentally disabled person.

3.2 Product Safety Symbols

The symbols below are used on the mobility scooter to identify warnings, mandatory actions, and prohibited actions. It is very important for you to read and understand them completely.

Scooter information label.



DOES NOT meet ISO 7176-19 standards for occupied transport in a motor vehicle. When travelling in a motor vehicle, do not sit in your Travel Scooter.



Fully charge batteries before operating.

Remove key from an unattended Travel Scooter.



Apollo scooter is not suitable for use as a seat for an occupant when in a motor vehicle.



Contact your local recycling center or authorized provider for information on proper recycling of product components.



Indicates component is for indoor use only.



Contains Lead.



Your product must be disposed of according to applicable local and national statutory regulations. Contact your local recycling center or authorized provider for information on proper disposal of product components.



Indicates a potentially hazardous situation which, if not avoided, could result in death or severe injury. Property damage may also result.



Indicates electrical shock hazard.



EMI-RFI - This product has been tested and passed at an immunity level of 20 V/m.



Indicates that explosive conditions exist.



Corrosive chemicals contained in batteries.



Pinch/Crush points exist.



Indicates a mandatory action that should be performed as specified in order to avoid a hazardous condition/situation. Failure to perform mandatory actions can lead to personal injury and/or equipment damage.



Read and follow the information in the owner's manual.



Indicates maximum weight capacity. Stay within the specified weight capacity of your product.



Use only AGM or Gel-Cell batteries to reduce the risk of leakage or explosive conditions.



Wear safety goggles.



N = Neutral (Brakes disengaged; unit in Freewheel Mode)



D = Drive (Brakes engaged; unit in Drive Mode)



Indicates a prohibited action that should not be performed at any time or in any circumstances. Performing a prohibited action can cause personal injury and/or equipment damage.



Do not use batteries with different amp-hour (Ah) capacities. Do not mix old and new batteries. Always replace both batteries at the same time.



Do not mix AGM and Gel-Cell batteries. Always use batteries of the same type and chemistry.

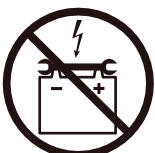

Keep tools and other metal objects away from battery terminals. Contact with tools can cause electric shock.

3. Safety Guidelines



Do not allow unsupervised children to play near the scooter while the batteries are charging.



Removal of grounding prong can create electrical hazard. If necessary, properly install an approved 3-pronged adapter to an electrical outlet having 2-pronged plug access.



Do not connect an extension cord to the AC/DC converter or the battery charger.



Indicates flammable material. Do not expose to heat sources such as open flame or sparks. Do not transport batteries with flammable or combustibe items.



Avoid exposure to rain, snow, ice, salt, or standing water whenever possible. Maintain and store in a clean and dry condition.



Do not remove anti-tip wheels.



Keep your hands away from the tyres when driving. Be aware that loose fitting clothing can become caught in the drive tyres.



Do not engage freewheel mode on an incline.



Do not engage freewheel mode on a decline.

24V 12AH

Battery capacity label

24V 20AH

Battery capacity label

3.3 Modification

Do not modify, remove, disable, or add any parts, features, or functions on your mobility scooter. MOBIAK offers a wide variety of accessories for your mobility scooter to help accommodate your needs.



WARNING – Do not modify your mobility scooter in any way; doing so will void the warranty.

3.4 Safety Check



ATTENTION – Inspect the following components before each use:

- Electrical connections and wire harness – secure and free from corrosion
 - Batteries – fully charged and free from corrosion
 - Brake – check the electromagnetic brake is functioning
 - Folding system – ensure the scooter is fully folded out
 - The condition of the tires – make sure they are not damaged or excessively worn
- If you notice a problem please contact your authorised **MOBIAK** Provider for assistance.

3.5 Weight Capacity

This mobility scooter is designed and produced solely to transport one person with a maximum weight of 136kg. It is not designed to transport goods or objects or use other than the transport previously described.



WARNING – Exceeding the maximum weight capacity will void your warranty. MOBIAK will not be held responsible for injury or damages resulting from failure to observe weight capacities.

3.6 Transporting Your Scooter

When transporting your mobility scooter by vehicle, it should be securely stowed in the back of a van, truck, or car boot. In order to ensure the safety of the user and to ensure that the mobility scooter is not damaged during handling, only the following positions should be lifted:

- a. The handle of the rear shell.
- b. Steering column.
- c. Front bumper

Adjustable parts should be removed or properly secured during transport. Your mobility scooter is suitable for land and maritime transport.



Do not sit in your mobility scooter while in a moving vehicle.

3.7 Incline Guidelines

Use caution when approaching inclines or declines; if necessary lower the speed before traveling on a slope.

When traveling up an incline, you need to try to keep the mobility scooter moving forward. If you must come to a stop, use caution and slowly accelerate the scooter forward.

When traveling down an incline, lower the speed on your mobility scooter to the lowest setting, and proceed cautiously. If the scooter is traveling down the incline faster than you expected, slowly release the throttle to come to a stop, then slightly push the throttle forward to continue safely down the incline.



WARNING – Drive your mobility scooter straight up or down an incline, never backward. Erratic movements or back and forth patterns may increase the chance of tipping. Changes in inclines may decrease stability. Under any circumstances, do not travel on a slope greater than the maximum stability angle for this mobility scooter.

3.8 Outdoor Operation & Inclement Weather Precautions

While your mobility scooter is purposed for in-home use to assist you in daily living activities, MOBIAK understands there are times you need to operate the scooter outdoors and has designed it to perform superbly on level outdoor surfaces.



ATTENTION – When operating outdoors, avoid uneven terrain, soft surfaces, tall grass, loose gravel, loose sand, freshwater, saltwater, edges of streams, lakes, or oceans. If you are unsure about a surface, avoid it.

Exposure to inclement weather should always be avoided. If you find yourself caught in inclement weather while operating your mobility scooter, proceed to the closest shelter immediately. Completely dry your mobility scooter before operating, charging, or storing.

3.9 Physical Limitations

This mobility scooter is designed and produced solely to transport one person with a maximum weight of 136kg, and the user must have good eyesight, lucid consciousness. You must exercise awareness, caution, care, and common sense when operating your scooter. Always keep in mind your own limitations, and substance use when operating your mobility scooter.



WARNING – Never use your mobility scooter while under the influence of alcohol or mind-altering substances. Never smoke while seated in your scooter. Damaged or worn upholstery increases the risk of fire hazards and should be replaced immediately.



ATTENTION – Be aware of precautions, warnings, and safety issues when taking prescribed or over-the-counter drugs while operating your mobility scooter.

3.10 EMI Information

Electromagnetic interference (EMI) tests have been shown to produce adverse effects on the performance and control of electrically powered mobility devices.

EMI can be produced from different sources such as cellular phones, two-way radios, radio stations, television stations, amateur radio transmitters (HAM), wireless computer links, microwave signals, paging transmitters, and transceivers used by emergency vehicles.

The EMI waves can cause unintentional movement of the scooter or damage to the controller. Every electrically-powered mobility device has a resistance to EMI. The higher the resistance level, the greater the protection. The intensity of the interference can be measured in volts per meter, V/m. At this time, current technology is capable of achieving an immunity level of 20 V/m, which provides protection from more common sources of EMI. Your scooter, with no modifications, has an immunity level of 20 V/m.

EMI becomes more intense as you move closer to the source. The EMI produced from hand-held

radios is of special concern. It is possible to unintentionally bring high levels of EMI very close to the scooter's control system, affecting your movement and braking. The warnings listed below are recommended to prevent possible interference with the control system of your scooter.



WARNING – Do not operate hand-held transceivers such as CB (citizens band) radios, or turn on personal communication devices, such as cellular phones, while the scooter is powered on.



WARNING – Drive your mobility scooter straight up or down an incline, never backward. Erratic movements or back and forth patterns may increase the chance of tipping. Changes in inclines.



WARNING – Be aware of nearby transmitters, such as radio or television stations, and avoid close.

3.11 Fireproof performance

Ignitability of upholstery according to EN1021-2 .

4. Your Product

The Apollo mobility scooter is easy to operate and is primarily intended for indoor use. It is foldable, which makes it very compact to store or transport. The following picture shows all parts that are relevant for the user/driver. In the operation and maintenance section, these parts are described if applicable. The separable has the brakes on top of the rear cover.



Figure 1. Important parts

- | | | |
|----------------------|--------------------|-----------------------------|
| 1. Operating console | 4. Battery package | 7. Seat & Back |
| 2. Handgrip | 5. Front wheel | 8. Free-wheel lever |
| 3. Steering column | 6. Footplate | 9. Rear wheel / drive wheel |

4.1 Manual Freewheel Lever

Whenever you need or want to push your Travel Scooter for short distances, you can put it in freewheel mode.

1. Locate the manual freewheel lever at the top right of the rear frame.
2. Push forward on the manual freewheel lever to disable the drive system and the brake system. You may now push your Travel Scooter.
3. Push the manual freewheel lever rearward to reengage the drive and the brake systems; this takes your Travel Scooter out of freewheel mode.



WARNING – Before placing your Travel Scooter into or taking it out of freewheel mode, remove the key from the key switch. Never sit on a Travel Scooter when it is in freewheel mode. Never put a Travel Scooter in freewheel mode on any incline. When your Travel Scooter is in freewheel mode, the braking system is disengaged.

- Disengage the drive motors only on a level surface.
- Ensure the key is removed from the key switch.
- Stand to the side of the scooter to engage or disengage freewheel mode.
- Never sit on a Travel Scooter to do this.
- After you have finished pushing your Travel Scooter, always return it to the drive mode to lock the brakes.



- | | |
|----------------------------|--------------------------|
| 1. Battery condition meter | 4. Speed adjustment dial |
| 2. Throttle control lever | 5. Horn |
| 3. Key switch | |

4.2 Battery Condition Meter

When the key is fully inserted into the key switch to power up your scooter, this meter indicates approximate battery strength. For further information on the battery condition meter, see 9. "Batteries and Charging."

4.3 Throttle Control Lever

This lever allows you to control the forward speed and the reverse speed of your Travel Scooter up to the

- maximum speed you preset with the speed adjustment dial.
- Place your right hand on the right handgrip and your left hand on the left handgrip.
- Use your right thumb to push the right side of the lever to disengage your Travel Scooter's brakes and move forward.
- Release the lever and allow your Travel Scooter to come to a complete stop before pushing the other side of the lever to move in reverse.
- When the throttle is completely released, it automatically returns to the center "stop" position and engages your Travel Scooter's brakes.

4.4 Key Switch

- Insert the key into the key switch to power up (turn on) your Travel Scooter.
- Pull the key out of the key switch to power down (turn off) your Travel Scooter.

Although the key can be left in the key switch when the Travel Scooter is powered down, we recommend removing it to prevent unauthorized use of your Travel Scooter.

4.5 Speed Adjustment Dial

This dial allows you to preselect and limit your Travel Scooter's top speed.

- The image of the bird represents the slowest speed setting.
- The image of the airplane represents the fastest speed setting.

4.6 Horn Button

This button activates a warning horn. Your Travel Scooter must be turned on for the horn to be operational. Do not hesitate to use the warning horn when doing so may prevent accident or injury.

5.1 Before getting onto your travel scooter

- Have you fully charged the batteries? See 9. "Batteries and Charging."
- Is the manual freewheel lever in the drive (rearward) position? Never leave the manual freewheel lever in the forward position unless you are manually pushing your Travel Scooter.
- Ensure the air temperature is between -13°F/-25°C to 122°F/50°C.
- Ensure the air humidity is between 30% to 70%.
- Ensure the atmospheric pressure is between 86 kPa to 106kPa.

5.2 Getting onto your travel scooter

1. Make certain that the key is removed from the key switch.



WARNING – Never attempt to get onto or off of your Travel Scooter without first removing the key from the key switch. This will prevent the Travel Scooter from moving if accidental throttle control lever contact is made.

2. Stand at the side of your Travel Scooter.
3. Disengage the seat rotation lever and rotate the seat until it is facing you.
4. Make certain that the seat is secured into position.
5. Position yourself comfortably and securely in the seat.
6. Disengage the seat rotation lever and rotate the seat until you are facing forward.
7. Make certain that the seat is secured into position.
8. Make certain that your feet are safely on the floorboard.

5.3 Pre-Ride Adjustment and check

- Is the seat at the proper height? See 6. "Comfort Adjustments."
- Is the seat secured into place?
- Is the tiller in a comfortable setting and secured into place? See 6. "Comfort Adjustments."
- Is the key fully inserted into the key switch?
- Does the Travel Scooter's horn work properly?
- Is your proposed path clear of people, pets, and obstacles?
- Have you planned your route to avoid adverse terrain and as many inclines as possible?

5.4 Operating your travel scooter



WARNING – The following can adversely affect steering and stability while operating your Travel Scooter:

- Holding onto or attaching a leash to walk your pet.
- Carrying passengers (including pets).
- Hanging any article from the tiller.
- Towing or being pushed by another motorized vehicle.

WARNING – Keep both hands on the tiller and your feet on the floorboard at all times while operating your Travel Scooter. This driving position gives you the most control over your vehicle.

- Set the speed adjustment dial to your desired speed.
- Press your thumb against the appropriate side of the throttle control lever.
- The electromechanical disc park brake automatically disengages, and the Travel Scooter accelerates smoothly to the speed you preselected with the speed adjustment dial.
- Pull on the left handgrip to steer your Travel Scooter to the left.

- Pull on the right handgrip to steer your Travel Scooter to the right.
- Move the tiller to the center position to drive straight ahead.
- To stop, slowly release the throttle control lever. The electronic brakes will automatically engage when your Travel Scooter comes to a stop.

NOTE: Your Travel Scooter's reverse speed is slower than that of the forward speed you preset with the speed adjustment dial.

5.5 Getting off of your travel scooter

1. Bring your Travel Scooter to a complete stop.



WARNING – Never attempt to get onto or off of your Travel Scooter without first removing the key from the key switch. This will prevent the Travel Scooter from moving if accidental throttle control lever contact is made.

2. Remove the key from the key switch.
3. Disengage the seat rotation lever and rotate the seat until you are facing toward the side of your Travel Scooter.
4. Make certain that the seat is secured into position.
5. Carefully and safely, get out of the seat and stand to the side of your Travel Scooter.
6. You can leave the seat facing to the side to facilitate boarding your Travel Scooter next time.

5.6 Power Down Timer Feature

Your Travel Scooter is equipped with an energy-saving automatic power-down timer feature designed to preserve your Travel Scooter's battery life. If you mistakenly leave the key in the key switch and in the "on" position but do not use your Travel Scooter for approximately 15 minutes, the Travel Scooter's controller shuts down automatically.

If the power down timer feature takes effect, perform the following steps to resume normal operation.

1. Remove the key from the key switch.
2. Reinsert the key and power up your Travel Scooter.

6.1 Delta tiller And Rear View Mirrors Adjustment (Optional)



Figure 3. Delta tiller And Rear View Mirrors

It is possible to adjust the rear view mirrors:

1. Move the cap ③ upwards.
2. Loosen the mirror screw.
3. Grasp the tube ② gently.
4. Rotate the tube ② and put the mirror ① in the desired position.

6.2 Tillers Angle Adjustment (Optional)

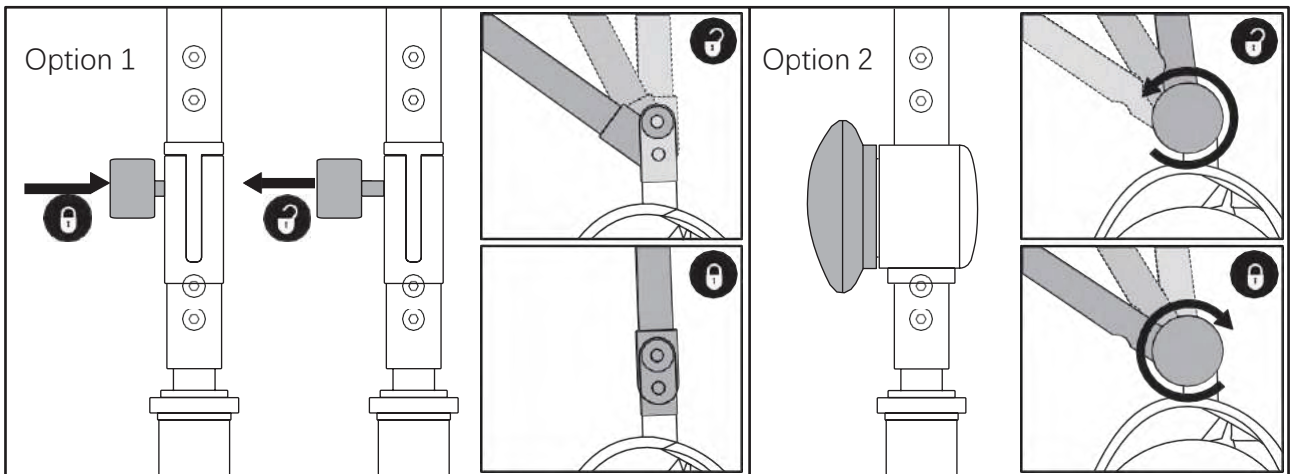

Figure 4. Tiller Adjustment Knobs

Tiller option 1: The Tiller is held in place by a knob. It supports only two states, includes vertically locked and unlocked. It has no angle adjustment function.

- Take the knob out of position of the hole of tiller to remove the fixation in order to fold the scooter.
- Hold tiller to maximum height and release the knob. It will automatically return to the tiller hole to secure the tiller.

Tiller option 2: The Tiller is held in place by a knob. It supports multi-angle adjustment. Height can be adjusted according to user requirements.

- Turn the knob counterclockwise to remove the fixation in order to fold the scooter.
- Hold tiller to proper height and turn knob clockwise to secure tiller.



WARNING – Remove the key from the keyswitch before adjusting the tiller or the seat. Never attempt to adjust the tiller or the seat while the Travel Scooter is in motion.



ATTENTION – In order to fully lower the tiller, you must first remove the seat and battery pack. Remove the seat by pulling it straight up and off of the Travel Scooter.

6.3 Seat Rotation Adjustment

The seat rotation lever, located on the right side of the seat base, secures the seat into several positions.

See figure 5.

1. Pull up on the seat rotation lever to disengage the seat.
2. Rotate the seat to the desired position.
3. Release the lever to secure the seat into place.

6.4 Armrest Width Adjustment

The armrest width can be adjusted inward or outward.

1. Loosen the armrest adjustment knobs.
2. Slide the armrests in or out to the desired width.
3. Tighten the armrest adjustment knobs.

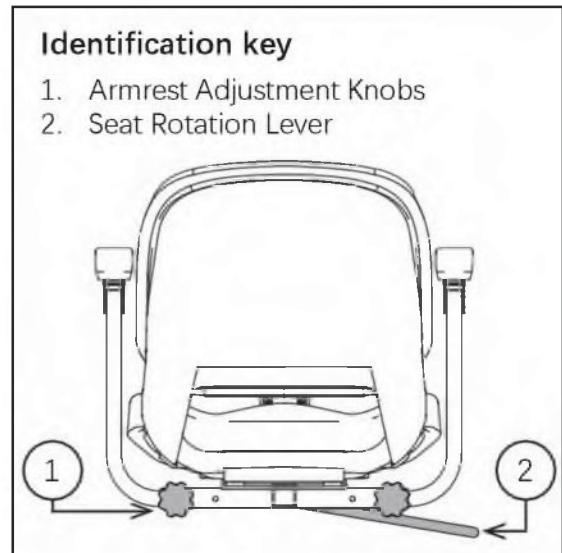

Figure 5. Seat Adjustments



ATTENTION – Pivot the armrests upward to aid in getting onto and off of your Travel Scooter.

6.5 Seat Height Adjustment

The seat can be repositioned to different heights.

See figure 6.

1. Remove the seat and battery pack from your Travel Scooter.
2. Use the attached ring to pull and remove the detent pin from the lower seat post.
3. Raise or lower the upper seat post to the desired seat height.
4. While holding the upper seat post at that height, align the adjustment holes of the upper and lower seat posts.
5. Fully insert the detent pin.
6. Replace the battery pack and seat.

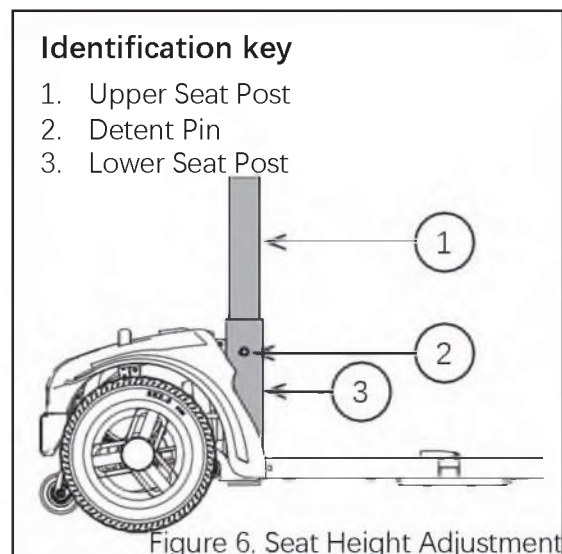

Figure 6. Seat Height Adjustment

7.1 Disassembly

You can disassemble the Travel Scooter into several pieces: ① the seat, ② the rear frame, ③ the front frame, ④ the basket, ⑤ the battery pack. No tools are required to disassemble or assemble your Travel Scooter. Always disassemble or assemble your Travel Scooter on a level, dry surface with sufficient room for you to work and move around—about 5 feet (1.5 meters) in all directions.

7.2 Disassembly Procedures



WARNING – Do not lift weight beyond your physical capability. Ask for assistance when necessary while disassembling or assembling your Travel Scooter.

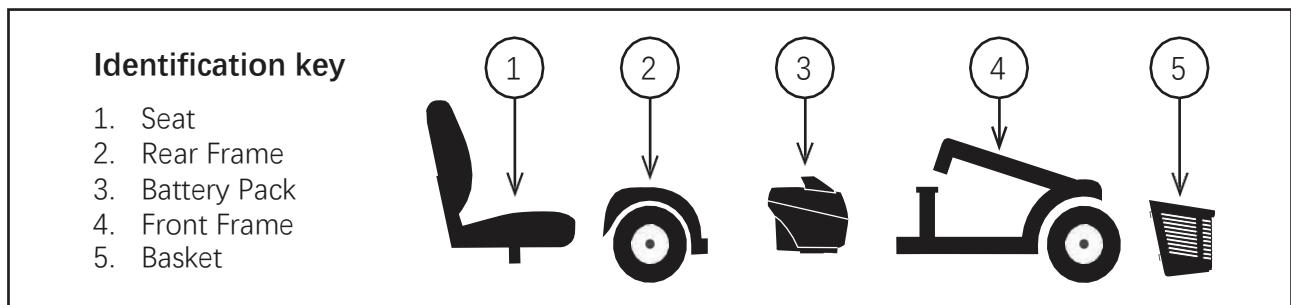

Figure 7. Disassembled Travel Scooter

1. Remove the seat by lifting it straight up and off of the Travel Scooter. If you encounter resistance when removing the seat, disengage the seat rotation lever and swivel the seat back and forth while lifting up on the seat.
2. Remove the battery pack by lifting the pack straight up and off of the Travel Scooter.

7.3 Frame Separation



ATTENTION – Before attempting assembly, tilt the rear half of the Travel Scooter slightly back on the anti-tip wheels as shown in figure 8.

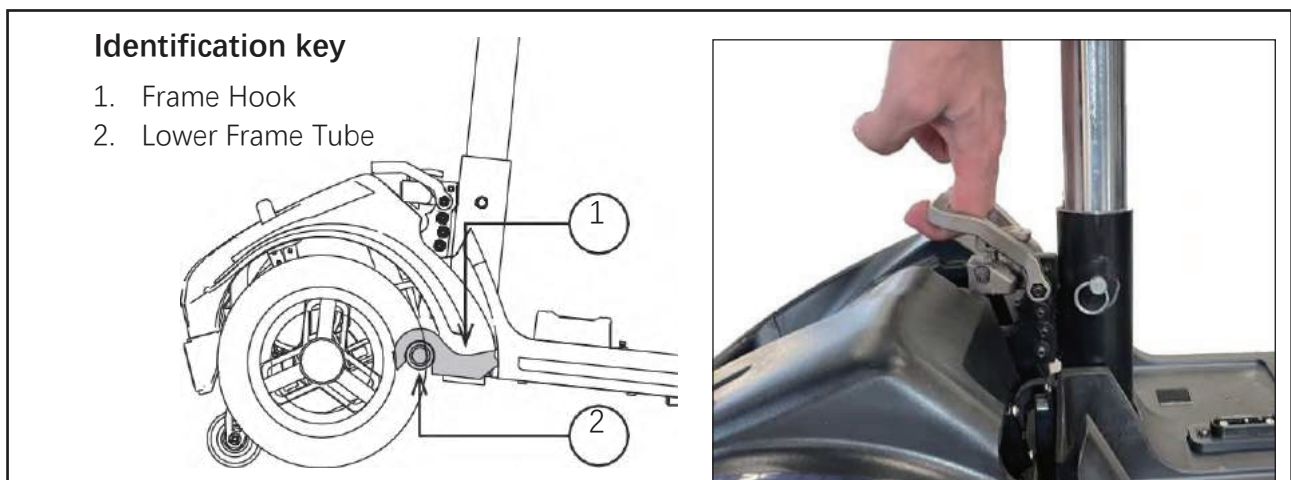

Figure 8. Frame Release Lever

1. With the seat and battery pack removed (see Disassembly Procedures on previous page), lower the tiller and tighten the tiller adjustment knob. See figure 4.
2. Lift up the frame release lever and move the front frame going forward until the front frame hooks are no longer resting on the rear frame tube.
3. Slowly separate the two parts of the Travel Scooter. See figure 8.

7.4 Assembly

1. Use the front frame release lever to lift the front frame as you align the framehooks of the front frame with the rear frame tube of the rear frame. See figure 8.
2. Once the frame hooks are over the rear frame tube, lower the front frame and pivot the rear frame simultaneously. This will engage the frame lock-up automatically. See figure 8.
3. Raise the tiller and fully secure the tiller adjustment knob. See figure 4.
4. Reinstall the battery pack.
5. Reinstall the seat and rotate it until it is secured into place.



WARNING – If the battery symbol light is flashing on the battery gauge then the scooter has detected a fault. In this happens, follow the procedure below:

1. Release the Wigwag paddle, then switch the scooter off and on. If this does not clear the fault then proceed to step 2 below.
2. Switch the scooter off and recharge the battery fully. If this does not clear the fault then proceed to step 3 below.
3. Count the number of flashes. The symbol will flash a number of times before a long pause. Count the number of flashes between pauses and report this to your dealer. The flash error codes are listed below for reference.

Flash	Description	Meaning
1	Battery Low	The batteries are running low. <ul style="list-style-type: none"> • Recharge the batteries.
2	Low Battery Fault	The batteries have run out of charge. Recharge the batteries. Check the battery and associated connections and wiring.
3	High Battery Fault	Battery voltage is too high. This may occur if overcharged &/or travelling down a long slope. If travelling down a slope, reduce your speed to minimise the amount of regenerative charging.
4	Current Limit Time-out or Controller too hot	The motor has been exceeding its maximum current rating for too long. <ul style="list-style-type: none"> • The scooter may have stalled. Turn the controller off, leave for a few minutes and turn back on again. • The motor may be faulty. Check the motor and associated connections and wiring.
5	Park Brake Fault	Either a park brake release switch is active or the park brake is faulty. <ul style="list-style-type: none"> • Check the park brake and associated connections and wiring. • Ensure any associated switches are in their correct positions.
6	Drive Inhibit	Either a Stop function is active or a Charger Inhibit or OONAPU condition has occurred. <ul style="list-style-type: none"> • Release the Stop condition (seat raised etc.) • Disconnect the Battery Charger. • Ensure the throttle is in neutral when turning the controller on. • The Throttle may require re-calibration.
7	Speed Pot Fault	The throttle, speed limit pot, SRW or their associated wiring may be faulty. <ul style="list-style-type: none"> • Check the throttle and speed pot and associated connections and wiring.
8	Motor Voltage Fault	The motor or its associated wiring is faulty. <ul style="list-style-type: none"> • Check the motor and associated connections and wiring.
9	Other error	The controller may have an internal fault. <ul style="list-style-type: none"> • Check all connections & wiring.

9. Batteries And Charging

Read the battery charging instructions in this manual and supply with the battery charger before charging the batteries. The battery condition meter on the tiller console indicates the approximate strength of your batteries using a color code. From right to left on the meter, green indicates fully charged batteries, yellow a draining charge, and red indicates that an immediate recharge is necessary. To ensure the highest accuracy, the battery condition meter should be checked while operating your Travel Scooter at full speed on a dry, level surface.

9.1 First Charge

Your mobility scooter requires two long-lasting, 12-volt, deep-cycle batteries that are sealed and maintenance-free.

They are recharged by the supplied off-board charging system. Charge your mobility scooter's batteries for at least 8 to 14 hours prior to using it for the first time. Keep the batteries fully charged to keep your mobility scooter running smoothly.

9.2 Charging Your Scooter

The mobility scooter can be charged using the charging ports located on the scooter or on the battery pack. Plug the charger into the scooter or battery pack and then into the electrical outlet. When the batteries are fully charged, remove the charger from the scooter.

9.3 Operating Temperatures

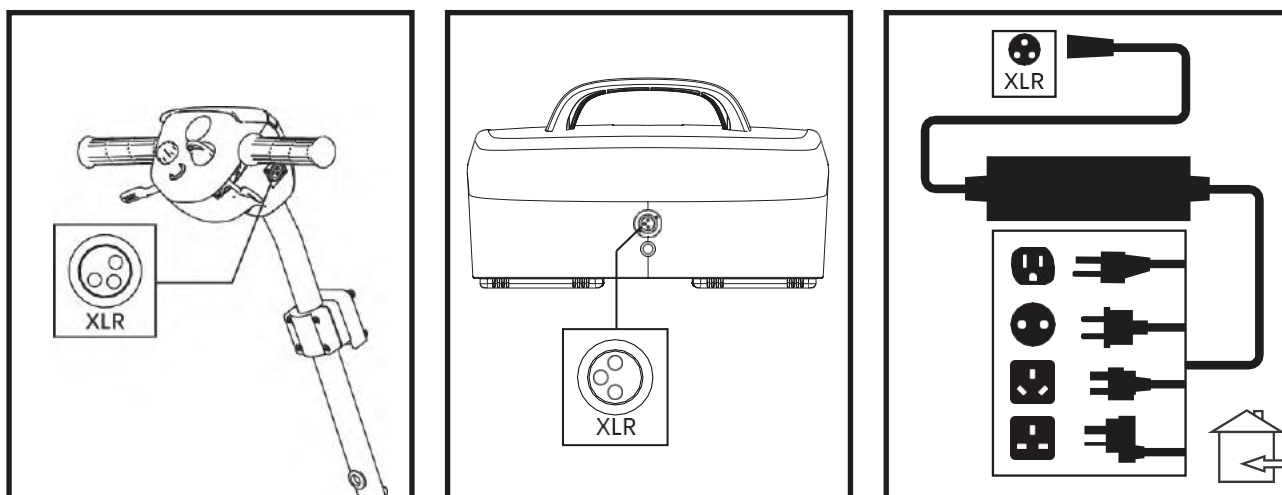

Your mobility scooter is designed to operate ideally between -10°C ~ 50°C (-14°F to 122°F). In extremely cold conditions, your batteries may freeze depending on the battery charge, usage, and composition of the batteries. In extremely hot conditions, your mobility scooter may operate at a slower speed. This is due to the safety mechanism built into the unit to prevent damage to the gearbox and other electronic functions when operating too hot.

9.4 Battery Operation and Charging

If you use your mobility scooter daily, charge its batteries as soon as you finish using it for the day. Your mobility scooter will be ready each morning. We recommend that you charge your mobility scooter's batteries for at least 8 to 14 hours after daily use. We recommend charging the batteries for an additional 4 hours after the battery charger indicates that charging is complete.

If you use your mobility scooter once a week or less, charge its batteries at least once a week for at least 24 hours.

9.5 Charging Batteries



ATTENTION – Keep your batteries fully charged and avoid deeply discharging your batteries. Refer to the manual supplied with the battery charger for charging instructions. We recommend charging your batteries for at least 48 continuous hours once per month to improve battery performance and battery life.

The light on your charger indicates different charge status.

Red Light – This means that charging is in operation.

Green Light – This means that bulk charging (95% charge) is complete and the charger is trickle charging the battery.



ATTENTION – There is a charger that inhibits function on your mobility scooter. The mobility scooter will not run, and the battery condition meter will not operate while the batteries are charging (when the battery pack is being charged on the mobility scooter).



WARNING – Removal of grounding prongs can create an electrical hazard. If necessary, properly install an approved 3-pronged adapter to an electrical outlet having 2-pronged plug access.

WARNING – Never use an extension cord to plug in your battery charger. Plug the charger directly into a properly wired standard electrical outlet.

WARNING – Do not allow unsupervised children to play near the mobility scooter while the batteries are charging. We recommend that you do not charge the batteries while the mobility scooter is occupied.

WARNING – Explosive gases may be generated while charging the batteries. Keep the mobility scooter and battery charger away from sources of ignition such as flames or sparks and provide adequate ventilation when charging the batteries.

WARNING – You must recharge your mobility scooter's batteries with the supplied off-board charger. Do not use an automotive-type battery charger.

WARNING – Inspect the battery charger, wiring, and connectors for damage before each use. Contact your authorized Provider if the damage is found.

WARNING – Do not attempt to open the battery charger case. If the battery charger does not appear to be working correctly, contact your authorized Provider.

WARNING – Be aware that the battery charger case may become hot during charging. Avoid skin contact and do not place on surfaces that may be affected by heat.

WARNING – If your battery charger has not been tested and approved for outdoor use, then do not expose it to adverse or extreme weather conditions. If the battery charger is exposed to adverse or extreme weather conditions, then it must be allowed to adjust the difference in environmental conditions before use indoors.

Your mobility scooter requires a minimal amount of care and maintenance. If you do not feel confident in your ability to perform the maintenance listed below, you may schedule inspection and maintenance at your authorized provider. The following areas require periodic inspection or care and maintenance.

10.1 Tire

Regularly inspect your mobility scooter's tires for signs of damage or wear.

10.2 Wheel Replacement

Your mobility scooter is equipped with PU tyres. If you have a damaged or worn tire, the entire wheel must be replaced. Contact your authorized provider for information regarding replacement wheels for your mobility scooter.



WARNING – Wheels on your mobility scooter should only be serviced/replaced by a qualified technician. Be sure that the key is removed from the key switch and the scooter is not in freewheel mode before performing this procedure.

10.3 Exterior Surfaces

Bumpers, tires, and trim can benefit from an occasional application of a rubber or vinyl conditioner.

10.4 Cleaning and Disinfection

Use a damp cloth and mild, non-abrasive cleanser to clean the plastic and metal parts of your mobility scooter. Avoid using products that may scratch the surface of your mobility scooter. If necessary, clean your product with an approved disinfectant. Make sure the disinfectant is safe for use on your product before application.



WARNING – Follow all safety instructions for the proper use of the disinfectant or cleaning agent before applying it to your product. Failure to comply may result in skin irritation or premature deterioration of upholstery or mobility scooter finishes.

10.5 Battery Terminal Connections

Make certain that the terminal connections remain tight and are not corroded.

10.6 Wiring Harnesses

- Regularly check all wiring connections.
- Regularly check all wiring insulation, including the charger power cord, for wear or damage.
- Have your authorized Provider repair or replace any damaged connector, connection, or insulation that you find before using your mobility scooter again.

10.7 Daily Checks

With the power turned off, check the throttle. Make sure it is not bent or damaged and that it returns to the neutral position when you release it. Do not try to repair it. See your authorized provider if there is a problem.

Visually inspect the tiller cable. Make sure that it is not frayed, cut, or has any wires exposed. See your authorized provider if there is a problem.

Check for flat spots on solid tires. Flat spots could adversely affect stability.

Inspect the armrests for loose hardware, stress points, or damage. See your authorized provider if there is a problem.

Check the brakes. This test should be carried out on a level surface with at least 3 feet (1 meter) of clearance around your scooter.

10.8 Weekly Checks

Inspect the controller and charger connectors for corrosion. Contact your authorized provider if necessary.

Check for proper tire inflation if equipped with pneumatic tires. If a tire does not hold air, contact your authorized provider for replacement of the tube.

10.9 Monthly Checks

- Check that the anti-tip wheels do not rub the ground when you operate the mobility scooter.
- Check for extreme wear on the anti-tip wheels. Replace them as necessary.
- Check for tire wear. See your authorized provider for repair.
- Keep your mobility scooter clean and free of foreign material, such as mud, dirt, hair, food, drink, etc.

10.10 Yearly Checks

Take your mobility scooter to your authorized provider for yearly maintenance, especially if you use your mobility scooter on a daily basis. This helps ensure that your mobility scooter is functioning properly and helps prevent future complications.

10.11 ABS Plastic Shrouds

If your mobility scooter has a body shroud with a glossy finish, the body shroud has been sprayed with a clear sealant coating. You can apply a light coat of car wax to help it retain its high-gloss appearance. If your mobility scooter has a body shroud with a matte finish, use ONLY products developed for matte-finish paint. Do not use wax, detail spray, ArmorAll®, or any product made for a glossy paint.

10.12 Axle Bearings and The Motor/Transaxle Assembly

These items are all pre-lubricated, sealed, and require no subsequent lubrication.

10.13 Console, Charger, and Rear Electronics

Keep these areas free of moisture. Allow these areas to dry thoroughly if they have been exposed to moisture before operating your mobility scooter again.

10.14 Nylon Lock Nut Replacement

Any nylon insert lock nut removed during the periodic maintenance, assembly, or disassembly of the mobility scooter must be replaced with a new nut. Nylon insert lock nuts should not be reused as it may cause damage to the nylon insert, resulting in a less secure fit. Replacement nylon insert lock nuts are available at local hardware stores or through your authorized provider.

10.15 Storing Your Travel Scooter

If you plan on not using your mobility scooter for an extended period of time, it is best to:

- Fully charge its batteries prior to storage.
- Remove the battery pack from the mobility scooter.
- Store your Travel Scooter in a warm, dry environment.
- Avoid storing your Travel Scooter where it will be exposed to temperature extremes.
- Recommended storage temperature: -10°C/-14°F to 50°C/122°F.
- Ensure the atmospheric pressure is between 86 kPa to 106kPa.



WARNING – Operation under high temperature, tires becoming soft.
Operation under very low temperature, user gets freezing.
Operation under very low temperature, tires crack.

- Recommended storage humidity: 30% to 70%.



WARNING – High humidity content may affect the strength of the frame.

Batteries that are regularly and deeply discharged, infrequently charged, stored in extreme temperatures, or stored without a full charge may be permanently damaged, causing unreliable performance and limited service life. It is recommended that you charge the mobility scooter batteries periodically throughout periods of prolonged storage to ensure proper performance.

For prolonged storage, you may wish to place several boards under the frame of your mobility scooter to raise it off of the ground. This takes the weight off the tires and reduces the possibility of flat spots developing on the areas of the tires contacting the ground.

10.16 Disposal of Your Mobility scooter

Your mobility scooter must be disposed of according to applicable local and national statutory regulations. Contact your local waste disposal agency or authorized provider for information on proper disposal of packaging, metal frame components, plastic components, electronics, batteries, neoprene, silicone, and polyurethane materials.

11. Specifications

Apollo
2023-05

Model	APOLLO
Type	Scooter, rear wheel drive, Class A
Max. weight of user	136 kg
Max. speed (driving forward)	8 km/h
Min. braking distance at max. speed	8 km/h: 1500 mm
Endurance mileage	Battery: AGM 24 V, 12 Ah: 15 km
Maximum height of obstacle	45 mm
Maximum safe slope	6°
Minimum turning radius	1150 mm
Minimum width required to reverse	1250 mm
L x W x H Dimensions unfolded(mm)	1030 x 490 x 880
Total mass, battery included	43,5 kg (AGM 24 V, 12 Ah)
Carton net weight	4 kg
Carton gross weight	47,5 kg
Carton dimensions	113 x 52 x 54 cm
Weight of battery	9 kg
Maximum weight of single part (Front frame assembly)	15 kg
Effective seat depth	370 mm
Effective seat width	410-600 mm
Seat surface height at front edge	380 mm
Height footplate	110 mm
Angle seat surface	-8°
Motor	270 W, electromagnetic brake
Battery	Battery: AGM 24 V, 12 Ah
Controller	Dynamic 50A
Protection class	IP X5
Battery charger	Input : 100-240 VAC , 50-60Hz , 1.2-0.5A , Class II Output : 24VDC , 2.0A
Protection class of battery charger	IPX1
Insulation class of battery charger	Class 2
Max. sound level scooter motor	68 dB
EMC compatible according to	ISO 7176-21
gnitability of upholstery according to	EN 1021-2
Diameter rear wheels (number)	8 x 2.5 inches
Diameter front wheels (number)	8 x 2.5 inches
Suspension	N/A
Control (wig-wag)	Lever to start/stop movement
Operating console	Rotatable switch for speed control
Storage and use temperature	-10 °C to +50 °C
Humidity to store and use	30% ~ 70%
<p>We reserve the right to introduce technical changes. Measurement tolerance ± 15 mm /1,5 kg / 1,5° . * The theoretical action radius reduces if the scooter is frequently used on slopes, rough surfaces or to climb kerbs. The maximum driving distance is tested in ideal circumstances according to ISO7176-4.</p>	

Speed and range may vary with user weight, type of terrain, battery charge and condition. The information contained herein is correct at the time of publication; MOBIAK reserves the right to alter specifications.

Disclosure information (ISO)						
	min.	max.			min.	max.
Overall length with legrest	1045mm	1045mm		Seat plane angle	9°	9°
Overall width	485mm	485mm		Effective seat depth	410mm	410mm
Folded length	1045mm	1045mm		Effective seat width	435mm	435mm
Folded width	485mm	485mm		Seat surface height at front edge	85mm	85mm
Folded height	350mm	1004mm		Backrest angle	20°	20°
Total mass	45kg	45kg		Backrest height	370mm	370mm
Mass of the heaviest part	15kg	15kg		Footrest to seat distance	455mm	455mm
Static stability downhill	27°	27°		Leg to seat surface angle	90°	112°
Static stability uphill	24°	24°		Armrest to seat distance	200mm	200mm
Static stability sideways	10°	10°		Front location of armrest structure	485mm	485mm
Energy consumption	16km	16km		Handrim diameter	-	-
Dynamic stability uphill	8 °	8 °		Horizontal location of axle	20mm	20mm
Obstacle climbing	40mm	45mm		Minimum turning radius	1300mm	1300mm
Maximum speed forward	7.2mm	8mm		Maximum occupant mass	136kg	136kg
Minimum braking distance from max speed	240mm	1380mm		Required width of angled corridor	900mm	900mm
Required doorway entry depth	1300mm	1300mm		Required corridor width for side opening	1300mm	1300mm

12.1 Two (2) Year Limited Warranty

Structural frame components, including: seat support tube and welded frames, have two (2) years warranty.

12.2 One (1) Year Limited Warranty

All electronic parts and drivetrain, including controllers, battery chargers, differential, motor, wheels and brake, have a one (1) year warranty.

Servicing to the controller, battery or battery charger must be carried out by your authorised MOBIAK Provider. Any attempt to open or dismantle these items renders the guarantee void on that item.

12.3 Not Covered Under Warranty

This guarantee does not extend to those items which may need replacement due to normal wear and tear (tyres, belts, bulbs, upholstery, plastic shrouds, motor brushes, fuses, and batteries), or damage to the product caused by misuse or accident for which MOBIAK or its agent cannot be held responsible. This warranty does not include labor or service calls.

12.4 Batteries



ATTENTION – Gradual deterioration in performance due to being left in a discharged state, left in cold conditions for long periods of time, or worn out through heavy use is not covered.

Batteries are covered by a six (6) month warranty from the original manufacturer.

12.5 Service Checks and Warranty Service

Warranty service can be performed by an authorised MOBIAK Provider. Please contact your authorised MOBIAK Provider for advice on the current cost affecting the service visit.

12.6 Replacement Units

The availability of replacement units and/or spare parts is subject to the discretion of the provider, not the manufacturer. For more information regarding replacement units and/or spare parts, contact your authorised MOBIAK Provider.

Guidance and Manufacturer's Declaration

Below cables information are provided for EMC reference.

Cable	Max. cable length, Shielded/unshielded		Number	Cable classification
AC Power Line	170cm	Unshielded	1 Set	AC Power
DC Power Line	115cm	Unshielded	1 Set	DC Power

Important information regarding Electro Magnetic Compatibility (EMC)

This electrical medical equipment needs special precautions regarding EMC and put into service according to the EMC information provided in the user manual; The equipment conforms to this IEC 60601-1-2:2014 standard for both immunity and emissions. Nevertheless, special precautions need to be observed:

- The equipment with no ESSENTIAL PERFORMANCE is intended used in Home healthcare environment
- WARNING: Use of this equipment adjacent to or stacked with other equipment should be avoided because it could result in improper operation. If such use is necessary, this equipment and the other equipment should be observed to verify that they are operating normally”.
- The use of accessories, transducers and cables other than those specified or provided by the manufacturer of this equipment could result in increased electromagnetic emissions or decreased electromagnetic immunity of this equipment and result in improper operation.
- WARNING: Portable RF communications equipment (including peripherals such as antenna cables and external antennas) should be used no closer than 30 cm (12 inches) to any part of the model APOLLO series, including cables specified by the manufacturer. Otherwise, degradation of the performance of this equipment could result.”
- WARNING: If the use location is near (e.g. less than 1.5 km from) AM, FM or TV broadcast antennas, before using this equipment, it should be observed to verify that it is operating normally to assure that the equipment remains safe with regard to electromagnetic disturbances throughout the expected service life.

EMI Compliance Table (Table 1)

Table 1 - Emission

Phenomenon	Compliance	Electromagnetic environment
RF emissions	CISPR 11 Group 1, Class B	Home healthcare environment
Harmonic distortion	IEC 61000-3-2 Class A	Home healthcare environment
Voltage fluctuations and flicker	IEC 61000-3-3 Compliance	Home healthcare environment

EMS Compliance Table (Table 2-5)

Table 2 - Enclosure Port

Phenomenon	Basic EMC standard	Immunity test levels
		Home healthcare environment
Electrostatic Discharge	IEC 61000-4-2	±8 kV contact ±2kV, ±4kV, ±8kV, ±15kV air
Radiated RF EM field	IEC 61000-4-3	10V/m 80MHz-2.7GHz 80% AM at 1kHz
Radiated RF EM field	IEC 61000-4-3	20V/m 26MHz-2.5GHz 80% AM at 1kHz
Proximity fields from RF wireless communications equipment	IEC 61000-4-3	Refer to table 3
Rated power frequency magnetic fields	IEC 61000-4-8	30A/m 50Hz or 60Hz

Table 3 – Proximity fields from RF wireless communications equipment

Test frequency (MHz)	Band (MHz)	Immunity test levels
		Home healthcare environment
385	380-390	Pulse modulation 18Hz, 27V/m
450	430-470	FM, ±5kHz deviation, 1kHz sine, 28V/m
710	704-787	Pulse modulation 217Hz, 9V/m
745		
780		

810	800-960	Pulse modulation 18Hz, 28V/m
870		
930		
1720	1700-1990	Pulse modulation 217Hz, 28V/m
1845		
1970		
2450	2400-2570	Pulse modulation 217Hz, 28V/m
5240	5100-5800	Pulse modulation 217Hz, 9V/m
5500		
5785		

Table 4 – Input a.c. power Port

Phenomenon	Basic EMC standard	Immunity test levels
		Home healthcare environment
Electrical fast transients/burst	IEC 61000-4-4	±2 kV 100kHz repetition frequency
Surges Line-to-line	IEC 61000-4-5	±0.5 kV, ±1 kV
Conducted disturbances induced by RF fields	IEC 61000-4-6	3V, 0.15MHz-80MHz 6V in ISM bands and amateur radio bands between 0.15MHz and 80MHz 80%AM at 1kHz
Voltage dips	IEC 61000-4-11	0% U _r ; 0.5 cycle At 0°, 45°, 90°, 135°, 180°, 225°, 270° and 315°
		0% U _r ; 1 cycle and 70% U _r ; 25/30 cycles Single phase: at 0°
Voltage interruptions	IEC 61000-4-11	0% U _r ; 250/300 cycles

Table 5 – Signal input/output parts Port

Phenomenon	Basic EMC standard	Immunity test levels
		Home healthcare environment
Conducted disturbances induced by RF fields	IEC 61000-4-6	3V, 0.15MHz-80MHz 6V in ISM bands and amateur radio bands between 0.15MHz and 80MHz 80%AM at 1kHz



MOBIAC S.A
ΚΑΘΙΑΝΑ ΑΚΡΩΤΗΡΙΟΥ, ΧΑΝΙΑ - ΚΡΗΤΗ
ΚΑΘΙΑΝΑ ΑΚΡΟΤΙΡΙΟΥ ΧΑΝΙΑ - CRETE
T: +30 28210 63222 | WEB: www.mobiakcare.com