

yuwell

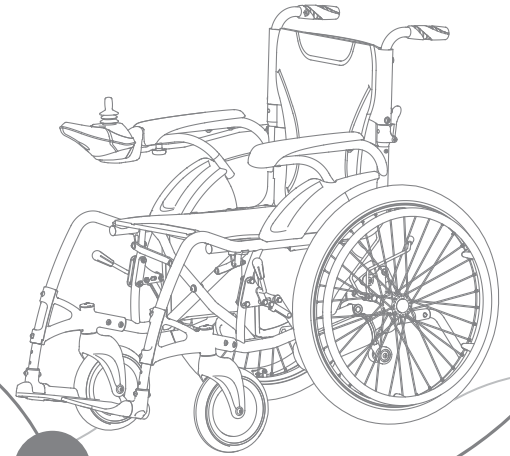

Electric Wheelchair

Product Operation and Technical Instructions

<http://www.yuwell.com>
Registrant/Manufacturer/After-sales Service Unit:
Jiangsu Yuyue Medical Equipment & Supply Co., Ltd.
Registered/Production Address: Yunyang Industrial Park, Danyang
Tel.: 0511-86900833
Fax: 0511-86900878
Revision Date: October, 2017

Please carefully read these instructions before using the product
Please refer to the qualification certificate or outer packaging for date of manufacture

530800-1A  纸

Contents

1. Preface.....	01
2. Safety Overview.....	01
3. Product Characteristics.....	03
4. Description of Symbols.....	05
5. Unpacking and Installation.....	06
6. Directions For Use.....	09
7. Daily Maintenance and Service.....	14
8. Transportation and Storage.....	19
9. Failure Diagnosis and Handling.....	20
10. Electromagnetic Compatibility.....	23
11. After-sales Service.....	30
12. Supplementary Instructions.....	31

1. Preface

Hello Customers!

- Thank you for your love of Yuyue and for purchasing a Yuyue Electric Wheelchair. The electric wheelchair carefully developed by Yuyue is light and convenient, efficient and energy-saving. It is flexible and safe to operate, and is well received by the majority of users.
- Before use, please carefully read these instructions so that you can better understand various functions of the electric wheelchair for better control. You should carry out the maintenance and service as required to ensure that the wheelchair is in good condition.
- For any questions, please contact the dealer or manufacturer and we will serve you wholeheartedly!

2. Safety Overview

- ⓘ Do not operate your electric wheelchair before reading and fully understanding these instructions.
- ⓘ Do not operate your electric wheelchair before the assembly and inspection are completed.
- ⓘ It is recommended that persons with unsound minds, slow responses and operational difficulties should not use the electric wheelchair.
- ⓘ Do not disassemble or modify the electric wheelchair or use any replacement parts not manufactured by the company.
- ⓘ Do not get into or out of the electric wheelchair when the controller is powered on or the electric wheelchair is in the manual mode and is not fixed by the pusher.
- ⓘ Do not use the electric wheelchair when the anti-roll wheel is not open or has broken down.
- ⓘ Do not tilt or lift the electric wheelchair to one side when it is being operated normally.
- ⓘ Do not stand on the pedal to prevent the electric wheelchair from rolling over.

- ⊗ Do not turn or steer on an incline.
- ⊗ To avoid accidents, the electric wheelchair should not be operated by two persons simultaneously.
- ⚠ The moving electric wheelchair should be decelerated to below 2km/h before turning.
- ⚠ Drive carefully in the lowest gear when going downhill.
- ⊗ Do not sit in the electric wheelchair when it is being transported.
- ⚠ Please check whether the wheel connections are secure and reliable.
- ⚠ Pull the controller joystick gently and do not pull back and forth on it rapidly.
- ⊗ The controller is the core part of the electric wheelchair. Do not park the electric wheelchair in the open air for a long time. The electric wheelchair should be parked indoors when it rains, to avoid moisture.
- ⚠ Before powering on the controller, confirm that the "Manual/Electric" clutch of the left and right motors or the handle is in the "Electric" gear.
- ⚠ Do not switch the "Manual/Electric" clutch handle of the motor to the "Manual" position while the wheelchair is running; if it is necessary to use radio communication devices such as mobile phones or laptops while in the electric state, please turn off the controller power of the electric wheelchair.
- ⊗ The electric wheelchair is suitable for flat ground and low inclines. Avoid driving on pavement with a slope greater than 6 degrees and driving over obstacles more than 4cm high.
- ⚠ It is strictly forbidden to cross places with horizontal gaps, such as sewers.
- ⚠ If the electric wheelchair is not used for a long time, turn off the power switch on the battery box.
- ⚠ This company's electric wheelchair is suitable for using outdoors, but can only be used in neighborhoods.
- ⊗ Contraindications: None
- ⊗ This electric wheelchair shall not be operated on the road, otherwise it is easy to cause traffic accidents.

3. Product Characteristics

(1). Scope of application

- This company's electric wheelchair is suitable for the disabled with difficulties walking and the elderly and infirm.

(2). Product components

- The product is composed of a frame, controller, motor, battery, pedal, handrail, front wheels and rear wheels.

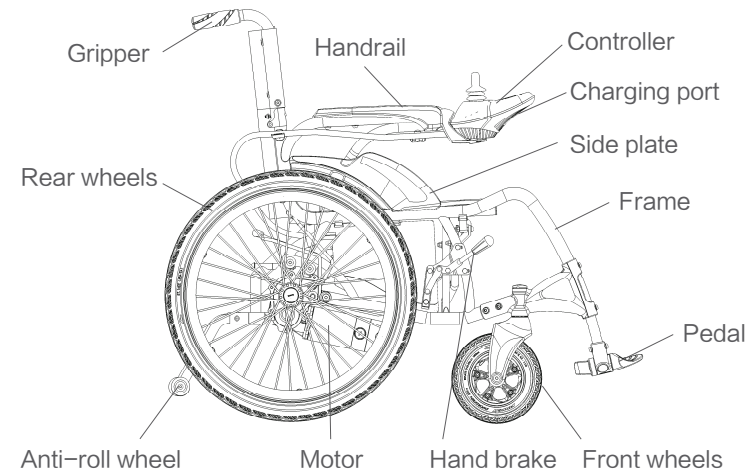

Refer to Figure 1 for the product's structural diagram

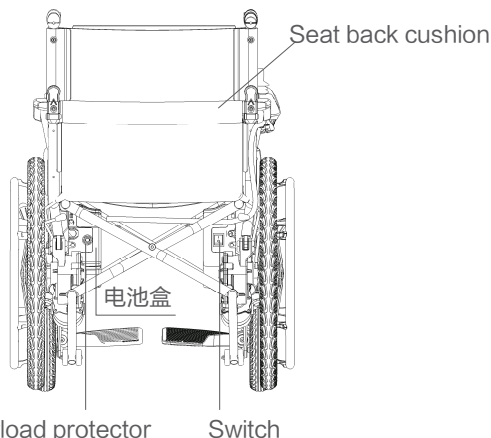

Refer to Figure 2 for the product's structural diagram

(3). Structural characteristics

- Motor: energy-saving and efficient.
- Frame: easy to assemble and disassemble, foldable.
- Intelligent controllers: power button, power display, universal joystick, horn.
- Electromagnetic braking system: safe and reliable.
- Anti-roll device.
- Battery: fully-sealed, maintenance-free.
- Two modes of operation: automatic electric drive mode and power boost mode.

(4). Technical parameters

1. Product type: outdoor model
2. Max. speed: $\leq 6\text{km/h}$
3. Ambient operating temperature: $-25^{\circ}\text{C}\sim+50^{\circ}\text{C}$
4. Power consumption: $\leq 2.5\text{kW}\bullet\text{h}/100\text{km}$
5. Load capacity: $\leq 100\text{kg}$







7. Braking performance on horizontal plane: $\leq 1.5\text{m}$
8. Endurance mileage: $\geq 20\text{km}$
9. Max. safety slope braking: $\leq 3.6\text{m}$ (6°)
10. Battery: lithium battery DC 24Vx18Ah; lead acid battery DC 24Vx21Ah
11. Obstacle clearance height: $\geq 40\text{mm}$
12. Groove clearance width: 100mm
13. Gradeability: $\geq 6^{\circ}$
14. Hill-holding performance: 9°
15. Static stability: $\geq 9^{\circ}$
16. Dynamic stability: $\geq 6^{\circ}$
17. Min. turning radius: 1.2m
18. Noise: $< 65\text{dB}$

The above parameters will vary depending on the weight of the occupant, road conditions and battery usage

- Normal working conditions:
 - Ambient temperature range: $-25^{\circ}\text{C}\sim+50^{\circ}\text{C}$
 - Relative humidity range: 25%~95%
 - Atmospheric pressure range: 86kPa~106kPa
- Internal power supply: DC24V \pm 5V
- Internal power supply equipment
- Electrical requirements: type B application part
- Mode of operation: continuous operation
- Fluid ingress protection degree: IPX4
- Motor power: about 130W for both left and right motors
- This equipment cannot be used in flammable anesthetic gas mixed with air or flammable anesthetic gas mixed with oxygen or nitrous oxide.

4. Description of Symbols

Symbols related to safety requirements of the electric wheelchair and their meaning

Symbols	Meaning
	Type B application part
	Note! Check the document attached to the electric wheelchair
IPX4	Splash-proof: a water splash in any direction will not cause any harmful effect
	Rain-proof
	Up
	Fragile
	ⓘ This sign indicates the mandatory contents (must be observed). The specific mandatory contents are expressed in words or drawings in or near. ⓘ The left figure indicates the "general mandatory contents"
	⊘ This sign indicates the prohibited contents (not allowed). The specific prohibited contents are expressed in words or drawings in or near. ⊘ The left figure indicates the "general prohibited contents"

5. Unpacking and Installation

- Take the electric wheelchair out of the box. Lift up the folded backrest, press down on the seat back tubes at both sides, open the electric wheelchair until the seat cushion and back cushion are fully expanded. Refer to Figure 3, Figure 4, Figure 5 and Figure 6.

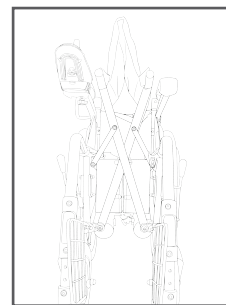

Figure 3

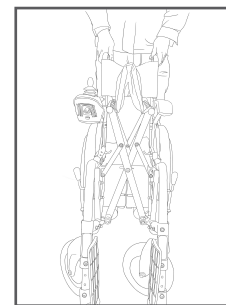

Figure 4

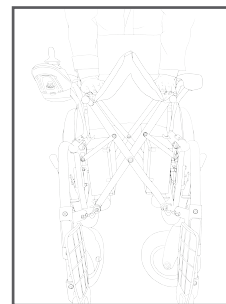

Figure 5

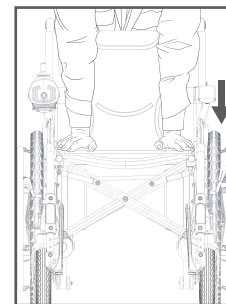

Figure 6

Note

To avoid pinching, do not hold the seat tubes with your hands when pressing down the seat cushion.

- Use of the backrest folding mechanism: hold the handle with both hands, lift up the backrest tube in a clockwise direction until the eject pin of the backrest folding device snaps into the eject pin hole, see Figure 7; pack up: press the buckle of the backrest folding device with your fingers, hold the backrest folding device with both hands. Fold it up in a counterclockwise direction after confirming that the eject pin has left the eject pin hole, see Figure 8.

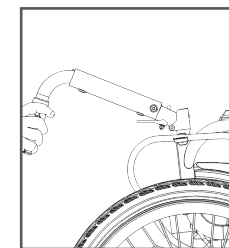

Figure 7

Note

To avoid pinching, do not put your fingers into the folded backrest .

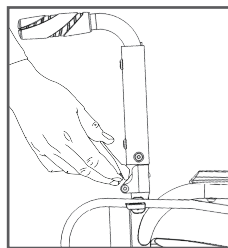

Figure 8

- Adjustment of pedal height: loosen the set screws on the fastener with a hexagon wrench, adjust the pedal to the appropriate height according to the height of the occupant and lock the set bolts, see Figure 9.

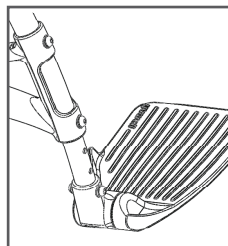

Figure 9

- Installation and removal of anti-roll wheel: hold the marble on the anti-roll wheel with your fingers while installing and insert it into the frame hole until the marble fastens into the marble hole of the wheelchair. While removing, hold the marble with one hand and pull the anti-roll wheel off backwards with the other hand, see Figure 10 (Note: tighten the cap nut on the inside while installing).

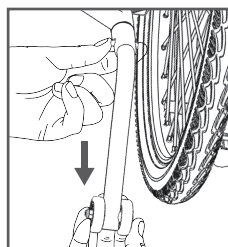

Figure 10

- Use of movable leg: when the electric wheelchair is provided with a movable leg, turn the movable leg from the position in Figure 11 to the position in Figure 12 along the rotational axis, ensuring that it rotates into the groove of the plastic part and open the pedal; the action sequence is reversed to folding back up. (Note: the function is only suitable for models provided with a movable leg)

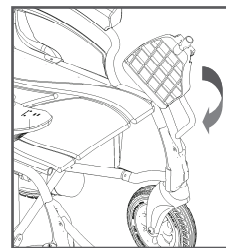

Figure 11

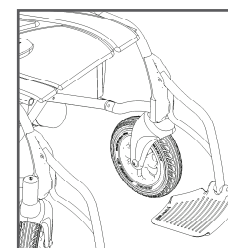

Figure 12

- Adjustment of controller: sit on the electric wheelchair, loosen the torx bolt, push the fixing rod of the controller backwards and forwards to the proper position and lock the torx bolt, see Figure 13. (The adjustment method is same if the controller is installed on the left side)

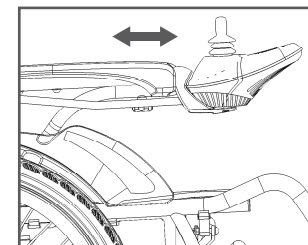

Figure 13

6. Directions For Use

(1). Function description of controller

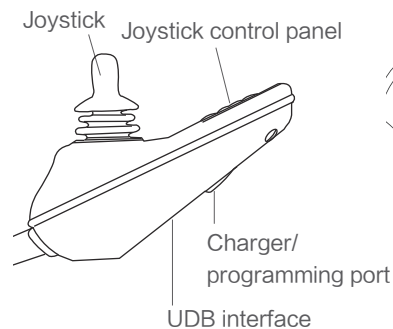

Figure 14

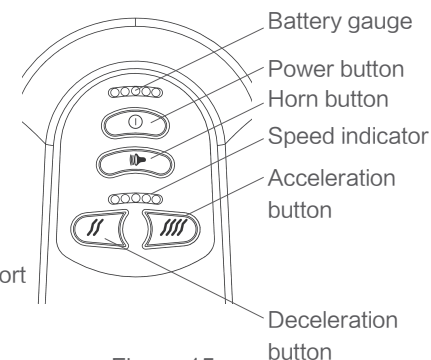

Figure 15

● Joystick

The joystick is mainly used to control the direction and speed of the wheelchair. The direction the joystick is pushed is the same as the direction of the wheelchair. The farther the joystick is pushed away from the center, the faster the wheelchair will move. The wheelchair will automatically brake when the joystick is released; when the wheelchair is stationary, do not push the joystick violently. Hold the joystick with your hand to move the electric wheelchair forwards and backwards and make turns. The electric wheelchair will automatically return and brake when the joystick is released.

● Battery gauge

The battery gauge is the indicator of the battery capacity. When the green LED lights are on, they indicate the battery capacity is full. When yellow or red LED lights are on, they indicate the battery capacity is not sufficient. Please charge the wheelchair as soon as possible to ensure normal operation.

● Speedometer

It displays the maximum speed setting of the wheelchair. 5 speed settings are available: 1st gear: lowest; 5th gear: fastest.

● Horn button

Press this button to sound the horn.

● Acceleration button

Press this button to increase the speed setting. The gear increases by 1 each time you press this button and won't change after it reaches 5th gear.

● Deceleration button

Press this button to decrease the speed setting. The gear decreases by 1 each time you press this button and won't change after it reaches 1st gear.

UDB interface

USB interface puts out 5V0.5A.

(2). Switching between electric driving and hand-pushing

When the wheelchair will be pushed manually instead of driven electrically, move the left and right motor clutch or handle to the "Manual" position; when driving electrically, switch the clutch or handle into the "Electric" position.

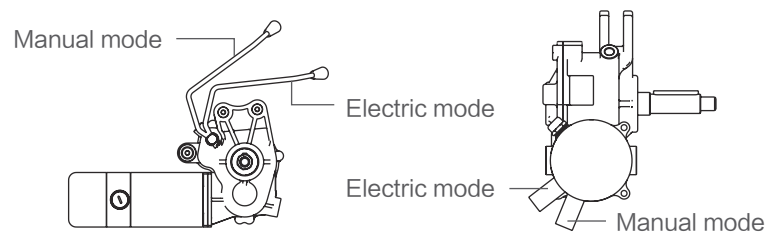

(3). Charger

The power supply charger is provided free of charge (to be used during the first test run). Customers are recommended to purchase the battery charger proposed by the company: lead-acid battery charger output DC24V3A and lithium battery charger output DC24V2A or 3A, which cannot be used together. The charger shall meet the requirements of GB9706.1-2007.

Note

- ▶ While charging, turn on the power switch on the battery box of the electric wheelchair and turn off the controller power button. Note: the power switch on the battery box is turned off when delivered. Make sure to turn on the power switch while charging. The switch is located on the back of the right battery box: "I": ON and "O": OFF, see Figure 16.

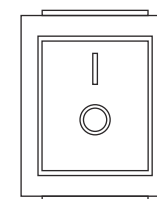

Figure 16

Note

- ▶ Insert the output plug of the charger into the lower slot of the controller, see Figure 17.

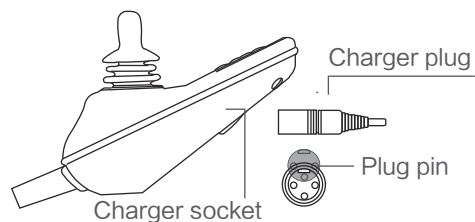

Figure 17

- ▶ To ensure the correctness of the circuit, do not arbitrarily change the circuit.
- ▶ To prevent burns or fires, do not disconnect the battery circuit during charging.

(4). Steps for normal driving

- Turn on the battery switch on the battery box and press "I" to switch it into normal operating condition, see Figure 16.
- Pull the clutch joystick of the two motors or the handle from the "Manual" to "Electric" position.

Note

Do not switch the clutch joystick on an incline. When switching on a level road, it is recommended to rotate the rear wheel slightly and then switch.

- Press the controller power button to check whether the electric wheelchair brakes effectively. If the wheelchair cannot be pushed, it indicates that the electronic brake is valid, otherwise you should contact the dealer or manufacturer.
- Lift the pedals up, sit in the electric wheelchair and then put the pedals down.

Note

Do not get into or out of the electric wheelchair by using the pedal. This may cause the electric wheelchair to tip over.

- Sit in the electric wheelchair, turn on the controller power button and the indicator light will turn on. At this time, the joystick should be in the middle position.
Focus your attention on the control of the wheelchair, which is especially important for first-time driving. Confirm that the handbrake is in the "non-braking" state before driving; the joystick can control the direction and speed simultaneously: the electromagnetic brake clicks and is released when you slowly push the joystick towards the driving direction, and the electric wheelchair will start moving; increase the pushing range of the joystick to accelerate, decrease the range to decelerate.
- If it is necessary to stop the moving electric wheelchair, just release and reset the joystick; if you suddenly pull the joystick or press the controller power button during forward movement, the wheelchair will quickly stop.
- When you stop on an incline, if the electromagnetic brake breaks down or the motor is in the "Manual" position or other special conditions occur, you can pull the hand brake in the direction as shown in Figure 18.

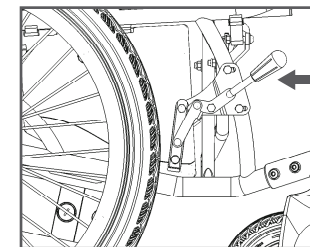

Figure 18

- The speed adjustment button of the controller can adjust the speed of the electric wheelchair. The occupant should select the maximum speed according to their physical condition and the road conditions.
- The electric wheelchair is suitable for driving on flat roads. Damage

may be caused to the transmission and control system when driving on muddy, hollow or uneven roads.

- The backrest angle for the adjustable electric wheelchair with backrest shall not be adjusted when on an incline. The backrest should be kept in the vertical state.

7. Daily Maintenance and Service

Note

Before servicing, press the power switch on the battery box to the "O" state.

- It is strongly recommended to have specialized personnel adjust and replace worn parts or to contact the manufacturer.

Inspection interval	Daily	Weekly	Monthly	Every 3 months	Every 6 months
Battery	✓				
Tire pressure		✓			
Wire		✓			
Hand brake			✓		
Frame				✓	
Controller				✓	
Motor				✓	
Connector				✓	
Seat back cushion					✓
Tire					✓
Electromagnetic brake					✓

Worn parts are replaced as follows (if it is difficult to replace, please contact the manufacturer promptly for a replacement):

1. Replacement of front wheel: loosen the screws with a wrench,

remove the front wheel, install the new front wheel, lock the screws, adjust the screw tightness and make sure the front wheel spins smoothly.

2. Replacement of rear wheel: have specialized personnel replace it or contact the manufacturer.

3. Seat (back) cushion: loosen the screws with a screwdriver, remove the seat (back) cushion, install the new seat (back) cushion and lock the screws with a screwdriver.

4. Replacement of handrail: loosen the screws with a wrench, remove and handrail, fasten the new handrail and lock the screws with a wrench.

- **Battery:** check the remaining battery capacity. If the battery reaches the end of its service life and should be replaced, please contact the supplier or the manufacturer or purchase a battery of the same specification locally.
- **Tire pressure:** it is recommended to inflate the tires of 200 X 45 – 110 and 310 X 50 – 203 to 260 kpa (maximum 325 kpa) and inflate the tires of 22 X 1.75 to 280 kpa (maximum 345kpa), which can be adjusted depending on weight and air temperature variation; the tires will leak gradually if they are stored for a long time or are not used, this is normal; please carefully read the following instructions to operate the wheelchair: a. when the tire pressure is not sufficient, (1) press the tire evenly with your hands, so that the tire and rim can fit uniformly; (2) inflate the tire to the appropriate state; b. when the tire is deflated, (1) inflate the tire to about 30% of the full air volume, press the tire evenly with your hands, so that the tire and rim can fit uniformly; (2) inflate the tire to the appropriate state.
- **Wire:** check the electrical parts and connecting wires for any damage. If any, please contact the supplier or have specialized personnel repair it. Do not repair it by yourself.
- **Hand brake:** the brake prevents the wheels from moving after the wheelchair is parked and cannot be used during driving; check

whether the brake has broken down. If it has, it can be adjusted and resumed.

- **Frame:** the frame surface coating should be wiped with a soft cloth and should be kept clean; lubricant is prohibited. if the frame cracks, please contact the supplier.
- **Service of controller:** clean the controller and joystick with a cloth dampened with a neutral diluted cleaner carefully. Never use abrasive materials or alcoholic detergents for cleaning. Protect the controller from damage during transportation of the wheelchair.
- **Motor:** check if there is any increase in oil leakage or noise. If any, please contact the supplier or manufacturer.
Maintenance of connector reliability: check that the screws and nuts on the body are tightened frequently and promptly handle the problems (if any) to ensure driving safety.
- **Seat back cushion:** wash the seat cover and backrest with warm water and diluted soapy water. Avoid keeping the wheelchair in a damp place.
- **Electromagnetic brake:** service brake. Let the wheelchair run straight at the maximum speed on a flat asphalt pavement. Release the controller joystick to automatically return it to the original position and measure the distance from the time of releasing the joystick to stopping. If the distance is larger than it was originally, the braking effect is reduced; if the distance is more than 1.5m, contact the supplier or manufacturer for repair.
- **Maintenance and service of battery:**
 1. Pay attention to the power indicator on the controller panel: if the green indicator is not lit, charge the battery as soon as possible; if the red indicator is lit, the battery capacity is seriously low. Charge the battery immediately to prevent the battery voltage from getting too low, thus affecting the battery's life.
 2. The battery is marked with obvious positive and negative electrode signs and a reliable connector is provided to ensure the normal

connection of the circuit. Non-specialized persons should not connect the circuit.

3. The battery is maintenance-free and replenishment of supplemental fluid is not required daily. During charging, the battery temperature will rise, but should not exceed 45°C; if the temperature exceeds 45°C, stop charging until the temperature drops below 35°C. If the wheelchair is parked for a long time, recharge the battery at least once a month.
4. The battery has its service life. If the trip mileage is significantly different from the nominal mileage after long time of normal operation, please replace the battery.
5. Do not use the battery at temperature of $\geq 50^{\circ}\text{C}$ or $\leq -20^{\circ}\text{C}$.
6. Keep the battery clean and dry. Do not hit the battery with hard objects. Keep the battery properly and keep it in a place out of reach of children.
7. The power switch on the battery box cuts off the battery power and reduces the natural power consumption of the battery. Turn off the power switch on the battery box when the wheelchair is not being used for a long time.
8. "Full capacity": develop the habit of maintaining the battery at full capacity and charge the battery in a timely manner according to usage, so that the battery is at "full capacity" long-term.
9. Replace battery
Press the power switch on the battery box to the "O" position for battery replacement;
 - (1). If lead-acid batteries is used, left and right battery boxes are provided and each battery box contains a lead-acid battery: red on the battery indicates the positive electrode and black indicates the negative electrode. The battery shall be replaced as follows:
 - a. Loosen the 6 self-tapping screws from inside of the electric wheelchair (i.e. back of the battery box) and open the back cover, see Figure 19. The methods are same for left side and right side;

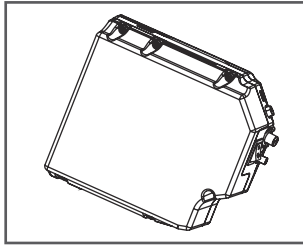

Figure 19

b. Take the battery out of the battery box, remove the positive and negative leads with a wrench, install the new battery and affix the positive and negative leads. The remaining wiring harness shall remain unchanged;

c. Pay attention to distinguish between the positive and negative electrodes on both sides of the wiring harness. For the right hand battery connecting wires, connect the red wire with the positive electrode (+) and connect the brown wire with the negative electrode (-); for the battery on the left, connect the red wire with the positive electrode (+) and connect the black wire with the negative electrode (-).

(2). If a lithium battery is used, only one battery box is provided at the right and the battery box only has a lithium battery: red on the battery indicates the positive electrode and black indicates the negative electrode. The battery shall be replaced as follows:

a. Loosen the 6 self-tapping screws from inside of the electric wheelchair (i.e. back of the battery box) and open the back cover (the illustration is same as that of the lead-acid battery);

b. Take the battery out of the battery box, separate the connector by hand, install the new battery and replace the connector. The remaining wiring harness shall remain unchanged.

- Waste should be disposed of in accordance with the relevant national environmental protection regulations.

8. Transportation and Storage

(1). Transportation

- ▶ Handle the product gently during transportation. Do not throw, turn over or apply great pressure to it.
- ▶ Folding steps: (see Figures 20, 21 and 22)

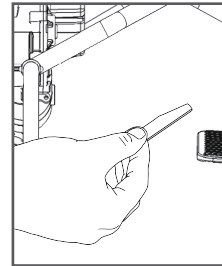

Figure 20
Fold up the pedals

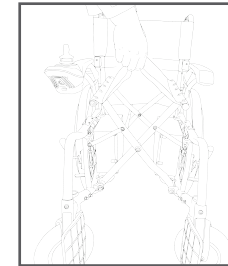

Figure 21
Lift up the cushion with both hands until the span length cannot be decreased

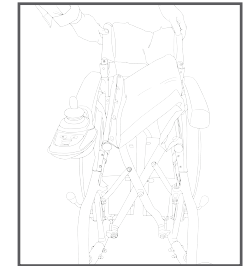

Figure 22
Put down the folded backrest

- Before boarding a plane, run out the battery capacity until the battery capacity is low (up to 1/3 of total battery capacity) and the red or red-yellow indicator lights are lit or the voltage is within 23V (lithium battery: within 26V).
- Turn off the power switch on the battery box during transportation.

(2). Storage

This product should be placed in dry and ventilated place and should not be stored in a place subjected to high temperatures and rapid temperature changes; this product should be separated from acid, alkali and other chemical corrosive items.

(3). Environmental restrictions for transportation and storage

Ambient temperature range: -40°C~+65°C

Relative humidity range: 10%~100%

Atmospheric pressure range: 86kPa~106kPa

9. Fault Diagnosis and Handling

- If the power signal is not available when the power button on the controller is pressed, confirm whether the power switch on the battery box is at the "I" position; if it is at the "O" position, press the power switch on the battery box to the "I" position; then, if the power signal is still not available for the power button on the controller, the current may be too large and the overload protector has cut off the power automatically. After the problem is eliminated, press the button to reset manually (see Figure 23).

Note: only the lead-acid battery is provided with an overload protector. If a lithium battery is used, it will cut off the power during overload. At this time, press the power switch from the "I" to "O" position and then back to the "I" position.

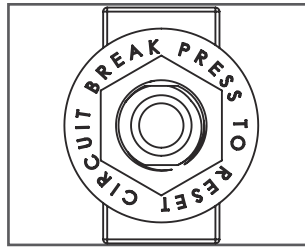

Figure 23

- In case of failure, the controller will sound an alarm and blink, and the corresponding faults can be handled according to the times of the alarm sounds.

The diagnostic number displayed by the product's built-in diagnostic function can reflect the nature of the abnormal condition. These abnormal conditions can still be detected without other service tools. Acoustic signal: the first 2 high-frequency sounds are the guide sounds and the subsequent sounds are the times of the alarm sounds in cycles.

Diagnostic sound	Diagnostic description	Recommended solutions
1	Low voltage	If the accumulator voltage is low, use it after charging; if the accumulator is damaged, replace it; the battery cannot be charged.
2	Right motor failure	Check the right motor for any loose connecting devices or motor wires.
3	Right brake	Check the right brake for any loose connecting devices or motor wires. Check the brake switch for any damage or poor switch contact.
4	Left motor failure	Check the left motor for any loose connecting devices or motor wires.
5	Left brake	Check the left brake for any loose connecting devices or motor wires. Check the brake switch for any damage or poor switch contact.
6	Overcurrent	Check the brake and motor transmission for any seizure. If the current detected by the ampere meter is not large, the controller may have broken down.
7	Rocker	The rocker is not reset or the rocker wire is broken or the connector has become loose.
8	Controller failure	Consult the service manufacturer.
9	Controller failure	Consult the service manufacturer.

- Most electric wheelchair faults are related to the battery, motor and controller.

No.	Description of faults	Reason analysis and elimination methods
1	The power indicator does not light when the controller power button is pressed	The connection between the battery and the controller is not correct. Re-connect it after inspection.
		The battery voltage is too low. If the indicator still does not light up after the battery is charged, the battery may have reached the end of its service life. Please replace the battery.
		If the controller breaks down, contact the dealer, manufacturer or after-sales service department.
2	Low battery voltage	The connector contact between the battery and the controller is not reliable. Please insert it again.
		The contact resistance between the battery connection is large; if the contact resistance is not large, the contact surface may be oxidized or loosened. Remove the oxide layer or install the connector properly.
		If the battery voltage is too low, it indicates that the battery has reached the end of its service life. Please replace the battery.
3	High battery voltage	The battery's charging voltage is too large. The voltage should not exceed 29.4V after charging is completed.
4	The motor does not work	The connector of the motor and the controller is not connected reliably. Please connect it again.

No.	Description of faults	Reason analysis and elimination methods
4	The motor does not work	If the motor breaks down, contact the dealer, manufacturer or after-sales service department.
5	Motor brake failure	The motor connector is not connected reliably. Please connect it again.
		The electric brake coil is damaged.
6	No charging indication	The connector of the motor and the controller is not connected reliably. Please connect it reliably again.
		The battery has reached the end of its service life or the charger is damaged. Please replace the battery or charger.
7	Trip distance is shortened after charging	The battery is not charged fully. Please charge the battery again.
		The battery is approaching the end of its service life. Please replace the battery.

10. Electromagnetic Compatibility

- This product complies with the requirements of the related content in the EMC (electromagnetic compatibility) Standards YY0505-2012 and GB/T18029.21 for the safe use of medical electrical equipment. The EMC Standards were developed for the safe use of medical appliances, and prescribe that the electromagnetic interferences from electromagnetic waves generated by appliances to other equipment and the electromagnetic interferences from other devices (mobile phones etc.) shall be controlled within a certain range. YY0505-2012 specifies that the details of the EMC environment for the safe

operation of the appliances shall be provided to the user. The following content describes the relevant technical description of EMC. (Refer to Y0505–2012 for details)

- The basic performance of this product described in the scope of application will not be affected by the electromagnetic environment stipulated in the EMC technical data.

■ Definition of EMC (electromagnetic compatibility)

EMC (electromagnetic compatibility) refers to the capability to satisfy the following two requirements.

1. It shall not send electromagnetic interference sounds outside the permitted range to other nearby electronic equipment. (Radiation)
2. The equipment can play its normal function in the electromagnetic environment where other electronic equipment sends out noise.

(Immunity)

■ Technical description related to EMC

(electromagnetic compatibility)

Medical electrical equipment shall be provided with special instructions about EMC and shall be used in accordance with the EMC information described below.

1. This product requires special instructions related to electromagnetic compatibility (EMC). Please use this product according to the EMC information described in this manual.
2. Portable and radio frequency (RF) communication equipment may affect this product.
3. Do not use this product adjacent to or stacked with other equipment. (Except for communication)
4. Do not use products other than special accessories, otherwise it may increase the radiation and decrease the immunity.

Warning: apart from the cables sold by the equipment or system manufacturer as spare parts of internal parts and components, the use of other accessories and cables may increase the equipment or system's emission or decrease the immunity.

Table 1 Guidance and manufacturer statement – electromagnetic emission

This electric wheelchair is intended to be used in the electromagnetic environment specified below and the purchaser or the user shall ensure this intended purpose.		
Emission test	Compliance	Electromagnetic environment – guidelines
RF emission GB4824	Group 1	This electric wheelchair shall only use RF energy for its internal functions. Therefore, its RF emission is low and the possibility of interfering with nearby electronic devices is minimal
RF emission GB4824	Class B	This electric wheelchair is suitable for use in the home and all facilities that are directly connected to the residential low-voltage supply network
Harmonic emission GB17625.1	NA	
Voltage fluctuation, flicker emission GB17625.2	NA	

(Corresponding to Table 201 in YY0505–2012)

Table 2 Guidance and manufacturer statement – electromagnetic immunity

This electric wheelchair is intended to be used in the electromagnetic environment specified below and the purchaser or the user shall ensure this intended purpose.			
Immunity test	IEC60601 Test level	Coincidence level	Electromagnetic environment – guidelines

Electrostatic discharge GB/T17626.2	±6kV, contact discharge ±8kV, air discharge	±6kV, contact discharge ±8kV, air discharge	The ground shall be made of wood, concrete or tiles and if the ground is covered by synthetic materials, the relative humidity shall be at least 30%
Electrical fast transient burst GB/T17626.4	±1kV to power cord	NA	NA
Surge GB/T17626.5	±1kV, line-to-line ±1kV, line-to-ground	NA	NA
Voltage sag, short interruption and voltage variation in the power input line GB/T17626.11	<5%UT for 0.5 weeks (>95% sag on UT), 40% UT for 5 weeks (60% sag on UT), 70% UT for 25 weeks (30% sag on UT), <5% UT for 5s (>95% sag on UT)	NA	NA
Power frequency magnetic field 50Hz GB/T17626.8	30A/m	30A/m	The power frequency magnetic field shall have the horizontal characteristics of the power frequency magnetic field in typical commercial or hospital environments

Note 1: UT refers to the AC grid voltage before the test voltage is applied

(Corresponding to Table 202 in YY0505-2012)

Table 3 Guidance and manufacturer statement – electromagnetic immunity

This electric wheelchair is intended to be used in the electromagnetic environment specified below and the purchaser or the user should ensure this intended purpose.			
Immunity test	IEC60601, test level	Coincidence level	Electromagnetic environment – guidelines
RF conduction GB/T17626.6 GB/T18029.21	3V/m 150kHz ~ 80MHz	NA	Portable and mobile RF communication equipment should not be closer to any part of the electric wheelchair (including the cables) than the recommended distance and the distance shall be calculated with the formula corresponding to the frequency of the transmitter. Recommended isolation distance $d = 1.2 \sqrt{P}$ $d = 1.2 \sqrt{P}$ 80MHz ~ 800 MHz $d = 2.3 \sqrt{P}$ 800MHz ~ 1.0GHz $d = 0.2 \sqrt{P}$ 26MHz ~ 800 MHz $d = 0.4 \sqrt{P}$ 800MHz ~ 2.5GHz Where: P – maximum output power of the transmitter supplied by the transmitter manufacturer, in watts (w), d – recommended isolation distance, in meters (m)
RF radio frequency radiation (charger) GB/T17626.3 GB/T18029.21	3V/m 80MHz ~ 1.0GHz	NA	
RF radio frequency radiation (wheelchair) GB/T17626.3 GB/T18029.21	20V/m 26MHz ~ 2.5GHz	20V/m	The field strength of the fixed RF transmitter is determined by investigation a of the electromagnetic field, which shall be lower than the coincidence level in each frequency range b. There may be interference near devices marked with the following symbols. 

Note 1: At frequencies of 80MHz and 800MHz, the formula with a higher frequency band shall be used. Note 2: These guidelines may not be suitable for all situations. The electromagnetic transmission is affected by absorption and reflection of buildings, objects and human bodies.

- a. In theory, the field strength of fixed transmitters such as wireless (cellular/cordless) telephones and ground mobile radio base stations, amateur radio, AM and FM radio and television broadcasts, cannot be accurately predicted. Investigation of electromagnetic sites shall be considered to evaluate the electromagnetic environment of fixed RF transmitters. If the field strength of the place where the electric wheelchair is located is higher than the above RF coincidence level, the electric wheelchair shall be observed to verify its normal operation. If abnormal performance is observed, it is necessary to take supplemental measures, such as re-adjustment of the direction or position of the electric wheelchair.
- b. The field strength should be less than 3V/m in the frequency range of 150kHz~80MHz.

(Corresponding to Table 204 in YY0505-2012)

Table 4 Recommended isolation distance between portable and mobile RF communication equipment and this device

This electric wheelchair is intended to be used in an electromagnetic environment with controlled radioactive radiation. The purchaser or user of the electric wheelchair can prevent electromagnetic interference by maintaining the minimum distance between portable and mobile radio frequency communication equipment (transmitter) and the electric wheelchair according to the maximum rated output power of the communication equipment.

Maximum rated output power of	Spacing distance of the corresponding transmitter at different frequencies/m				
	150kHz~80MHz $d = 1.2\sqrt{P}$	80MHz~800MHz $d = 1.2\sqrt{P}$	800MHz~1.0GHz $d = 2.3\sqrt{P}$	26MHz~800MHz $d = 0.2\sqrt{P}$	800MHz~2.5GHz $d = 0.4\sqrt{P}$
0.01	NA	NA	NA	0.02	0.04
0.1	NA	NA	NA	0.06	0.13
1	NA	NA	NA	0.2	0.4
10	NA	NA	NA	0.63	1.26
100	NA	NA	NA	2	4

For maximum rated output power of a transmitter not listed in the table above, the recommended isolation distance d (in m) can be determined by the formula in the corresponding transmitter frequency column, where P is the maximum rated output power of the transmitter supplied by the transmitter manufacturer, in watts (W). Note 1: At frequencies of 80MHz and 800MHz, the formula with a higher frequency band shall be used. Note 2: These guidelines may not be suitable for all situations. Electromagnetic transmission is affected by the absorption and reflection of buildings, objects and human bodies.

(Corresponding to Table 206 in YY0505-2012)

11. After-sales Service

Warranty instructions:

- Our company is responsible for return, replacement and repair if any quality problem not caused by human factors occurs to this product within one week after the date of sale. Our company will provide the free repairs if any quality problem not caused by human factors occurs to this product within one year after the date of sale under normal operation and storage conditions. For any quality problem of this product after one year after the date of sale, the user can send it to the company's after-sales service department, office or dealer with an invoice and warranty card and our company will repair the parts and components at a reasonable charge. If the user fails to provide the invoice, the warranty period will be extended by one month according to the company's batch number or date of production. Foreign users may send the product to our company for repair at their own expense.
- Service life: 3 years (except for wearing parts).
The warranty period of important parts is as follows:

No.	Parts	Warranty period
1	Frame	3 years
2	Controller	1 years
3	Motor	1 years

- The following conditions are not covered by the warranty:
 - ① Wearing parts: seat back cushion, tire, handrail and battery;
 - ② Faults caused by unauthorized demolition, repair and transformation of this product;
 - ③ Faults caused by accidental drops during operation and transportation;
 - ④ Damage caused by improper use or other accidental and human factors;
 - ⑤ Faults caused by failing to comply with the correct operation methods in these instructions;
 - ⑥ Damage caused by unpredictable natural

disasters (such as fires, earthquakes and floods); ⑦ No warranty card; ⑧ The product model recorded on the warranty card is inconsistent or is modified.

- The number is displayed on the cross bar of each electric wheelchair.

Note

If repairs are necessary, you can provide a circuit diagram, parts list and data required for repair. If the circuit has any problems, contact the manufacturer.















12. Supplementary Instructions

Name and content of toxic and hazardous substances or elements in the electric wheelchair
All right reserved: Jiangsu Yuyue Medical Equipment & Supply Co., Ltd.

Part name	Toxic and hazardous substances or elements					
	Lead and its compounds ≤1000PPM	Mercury and its compounds ≤1000PPM	Cadmium and its compounds ≤100PPM	Hexavalent chromium and its compounds ≤1000PPM	Polybrominated biphenyls ≤1000PPM	Polybrominated diphenyl ethers ≤1000PPM
Frame	○	○	○	○	○	○
Plastic parts	○	○	○	○	○	○
Tire	○	○	○	○	○	○
Wiring harness	○	○	○	○	○	○
Switch	○	○	○	○	○	○
Overload protector*	○	○	○	○	○	○
Screw	○	○	○	○	○	○
Packing materials	○	○	○	○	○	○

○ : indicates that the contents of the toxic and hazardous substance in all homogeneous materials of the part are below the limit specified in GB/T26575-2011.
* : indicates that the part may not be a product component.
Note: lead in steel material ≤3500PPM, lead in aluminum material ≤4000PPM, lead in copper material ≤4%; the contents of all 6 toxic and hazardous substances in the packing material are ≤100PPM.

Size and weight parameter table of electric wheelchair

Model	Total length mm	Total width mm	Total height mm	Seat width mm	Seat height mm	Seat depth mm	Handrail height mm	Handrail spacing mm	Seatrest height mm	Ground clearance of foot support mm	Front wheel inch	Rear wheel inch	Max. load capacity Kg	Net weight Kg	Description of characteristics
															
D130A	1040	680	910	430	440	430	225	450	400	100/190	8	22	100	Lead-acid: 38	Fixed handle, fixed foot, extended handrail
D130AL	1040	680	910	430	440	430	225	450	400	100/190	8	22	100	Lithium battery: 29	Fixed handle, fixed foot, extended handrail
D130B	995	615	910	430	440	430	225	450	400	100/190	8	12	100	Lead-acid: 37	Fixed handle, fixed foot, extended handrail
D130BL	995	615	910	430	440	430	225	450	400	100/190	8	12	100	Lithium battery: 28	Fixed handle, fixed foot, extended handrail
D130H	970	670	890	440	430	430	225	420	395	87	8	12	100	Lead-acid: 35	Fixed handle, movable foot, foldable back
D130HL	970	670	890	440	430	430	225	420	395	87	8	12	100	Lithium battery: 26	Fixed handle, movable foot, foldable back
D130M	1060	670	890	430	430	430	225	440	395	87	8	22	100	Lead-acid: 36	Fixed handle, movable foot, foldable back
D130ML	1060	670	890	430	430	430	225	440	395	87	8	22	100	Lithium battery: 27	Fixed handle, movable foot, foldable back

We reserve the right to change the technology and appearance of this product. Subject to change without notice.